

## LightLab R100 Rotating Mirror Intensity Distribution Photometer.

This system comprises:

- a) A 360 degree rotating mirror intensity distribution photometer with (optionally) mirror tilt function for varying photometric test distance.
- b) Computer automation electronics, including photo-detector system, computer interface control console, and computer.
- c) Computer software covering photometer control, data acquisition and report processing functions.
- d) Dedicated components for laboratory operation.

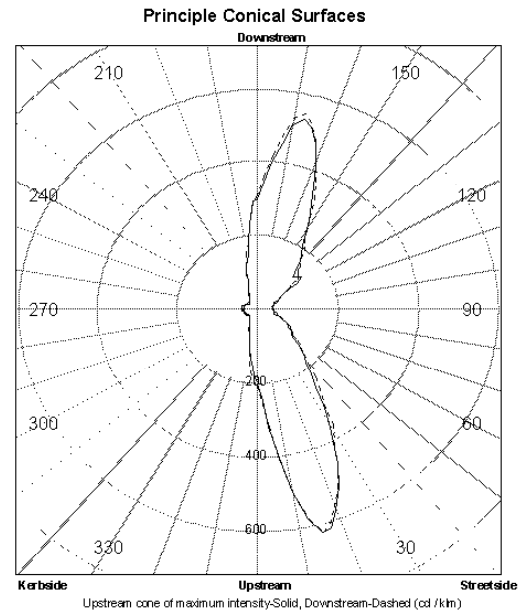

The R100 is a modern, sleek looking, laboratory grade photometer for the measurement of intensity distribution for all light sources.



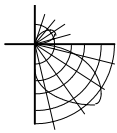

## LightLab R100 Rotating Mirror Intensity Distribution Photometer.

### Photometer assembly comprises:

- A.1** A free standing tower which supports a precision rotating mirror system and rotatable photometer head frame for photometering of all types of luminaires. Headframe is positively located in UP or DOWN position by precision locating mechanism to allow tests on luminaires such as uplights and bollards.
- A.2** A supported mirror and its counterbalance which rotates about a fixed shaft and is driven via a toothed belt with geared DC servo control motor through a harmonic drive gearbox with an angular resolution of better than  $0.001^\circ$ . Total system accuracy is better than 0.1 degrees. The design of the mirror mechanism requires no lubrication. Mirror motion is through a full 360 degrees, data acquisition is through a full 360 degrees.
- A.3** The mirror support structure is provided with a very rigid tilt mechanism as an optional extra which allows adjustment of the photometric test distance via precision machined tilt blocks. This allows the photometric test distance to be adjusted depending on the luminaire under test. Typical test distances vary from 8m (used for wide beam luminaires) to 30m (for narrow beam luminaires).
- A.4** A photometer head frame which carries a mechanism for the attachment of the luminaire, allowing 360 degrees of rotation of the luminaire about the vertical axis with an angular resolution of better than  $0.005^\circ$  and accuracy of better than 0.1 degrees. The luminaire rotation is motorised. The motorised raising and lowering of the photometric centre of the sample (to position the light centre at the axis of rotation) is controlled through the hand controller. The extent of travel of the raising and lowering is limited by over-travel limit switches.
- A.5** All three axes of motion (mirror, luminaire and up/down movement of luminaire) are powered by sealed drives with high reduction ratio, zero backlash, harmonic drive gearboxes requiring no maintenance or lubrication for the life of the photometer. The operation is inaudible with negligible power consumption. The position of all three axes is determined by high precision angle encoders.
- A.6** A high quality silvered mirror (in accordance with requirements of CIE Pub No 24 clause 4.4.3) with sealed edges. This backing board is secured to a separate steel frame to ensure mirror flatness and is manufactured flat within  $50\mu\text{m}$ . The size of the mirror is designed according to the maximum dimensions of the luminaire to be tested to avoid edge effects.
- A.7** Three lasers for the precise alignment of the luminaire and photocells to the rotation axis of the photometer mirror. The mirror rotation axis and luminaire rotation axis lasers are built into respective spindles and allow for extremely accurate positioning of the photocell and luminaire under test. Furthermore, photocell positioning accuracy can be tested with the simple push of a switch during calibrations.
- A.8** The photometer is capable of photometric measurements on luminaires with maximum luminous opening dimensions of 1510mm length x 650mm width and up to 50kg in weight while retaining stated accuracies. The maximum luminous opening of samples with 5' lamps is comfortably handled.

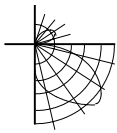

## LightLab R100 Rotating Mirror Intensity Distribution Photometer.

**A.9** The R100 operates in accordance with the requirements of the following standards:

Publication CIE No. 24 : Photometry of indoor type luminaires with tubular fluorescent lamps  
Publication CIE No. 27 : Photometry of luminaires for street lighting  
Publication CIE No. 70 : The measurement of absolute luminous intensity distribution.  
Publication CIE No. 84 : The measurement of luminous flux.  
Publication CIE No. 69 : Methods of characterising illuminance meter and luminance meter.  
Publication CIE No. 121 The photometry and goniophotometry of luminaires: Section 4

BS 5225: Part 1: 1975/8/85: Photometric data for luminaires : Part 1 Photometric Measurements.

**A.10** Levelling and alignment of the goniometer is done through precision machined alignment pads fitted to the goniometer tower.

**A.11** The operation of the goniometer is inherently safe. All movement commands issued to the goniophotometer axes are mediated by the software to ensure the motion is within the limits of operation. All linear axes are fitted with overtravel switches. The goniophotometer is fitted with emergency stop switches which will halt all motion independent of the computer system.

**A.12** All of the goniophotometer electronics are mounted within an industrial junction box for easy accessibility. Wiring diagrams for all of the electronics are supplied along with the identification of servicing test points.

**A.13** All electronic components in the goniophotometer are supplied by internationally recognised companies allowing simplified field servicing.

**A.14** A selection of photocells is available for the R100. The standard photocell is a high quality temperature stabilised cell with opal face to minimise effects of non-uniform illuminance. For other photocells please refer to the table of options.

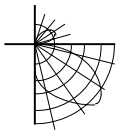

## LightLab R100 Rotating Mirror Intensity Distribution Photometer.

**Specification summary:**

Angular limits for rotational axes	Resolution	Fixture rotation < 0.005 ° Mirror rotation < 0.001 °
	Accuracy	All axes < 0.1 °
Electrical characteristics of supply	Option StVAR1005kV3	5 kW maximum supply Voltage regulation <= 0.1% THD <=1%
Electrical measurement Accuracy	Option WTR100	Voltage < 0.2%
	Option WTPR1003	Voltage < 0.1%
Photocell Specifications  All options have 35° C temperature stabilisation	Standard photocell	20 nA / lux response
	Option PhotR100	120 nA / lux response, CIE characteristics as per Photocell Table 1 in the summary section
Software	Control	Unlimited scriptable test formats, wizard based procedures, calibration tracking, diagnostics
	Report	Client formatting of test reports: interior, exterior, floodlight, lamp, street, 5 symmetry types, 4 lumen basis types
Sample characteristics	Horiz.dimensions	1510mm length x 650mm width
	Maximum power	Limited only by stabilised supply
System Supply		100 – 120V or 220 – 240V (50/60 Hz)

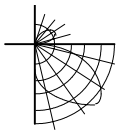

## LightLab R100 Rotating Mirror Intensity Distribution Photometer.

Comprises:

### B.1 Photoelectric Detector

All of the photodetectors supplied meet the following minimum specifications below, specific features of each photocell option are listed in the Specification Summary section.

Thermally stabilised Si-photovoltaic cell (35 degrees Celsius) with high accuracy  $V\lambda$  correction using the full filter method ( $f_1 < 1.0\%$ ,  $f_1 \leq 2.0\%$ , refer CIE Pub No 53). Photodetector comes complete with spectral response calibration certificate and separate power supply for the cell heater.

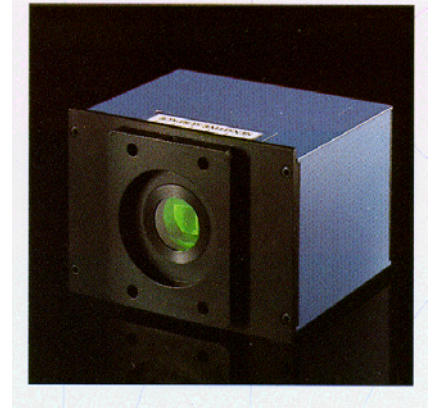

- very high shunt resistance ( $R_s$ ), giving the system a low overall noise gain.
- low shunt capacitance ( $C_s$ ), giving fast response to rapidly changing intensities.

Other photocells are available, please refer to the options.

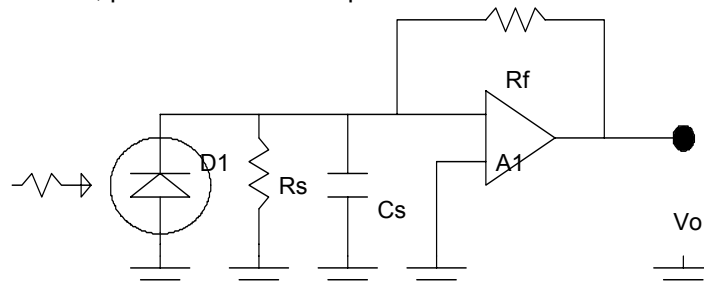

### Simplified Photocell Input Circuit.

- Noise gain a to  $R_f/R_s$
- Frequency response a  $1/(C_s \times R_f)$

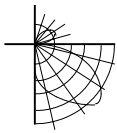

## LightLab R100 Rotating Mirror Intensity Distribution Photometer.

### **B.2 Photocell Interface**

The interface electronics used in the Model R100 Photometer drives the output from the photocell into a virtual earth (refer simplified photocell input circuit) via a low noise, low capacitance 'Triax' cable and will measure over the range 2nA (resolution 10fA) to 2mA (10nA resolution). Precision is 5 & 1/2 digits auto ranging. The unit is fully programmable via an IEEE-488 bus and has selectable 50Hz or 60Hz line integration to reduce noise. The interface electronics has an integral display so it can display the photocell value independently of the computer.

With the standard cell, at a nominal test distance of 8m, the dynamic range of the R100 mirror photometer is 1mcd to 1Mcd. The photocell can be set to perform measurements of either illuminance (lux or foot candles) or luminous intensity (candelas).

### **B.3 Computer**

The rotating mirror photometer is fully computer controlled and is therefore supplied complete with computer.

Specifications:

- IBM PC compatible, Pentium IV processor.
- 80 GB Hard disk.
- 512 Mb RAM.
- SVGA 15" colour screen and interface card.
- IEEE-488 interface card and software.
- An optional printer
- 19" rack mount industrial computer chassis and enclosure.

### **B.4 Hand Controller**

The portable hand controller, connected to the photometer, allows for manual set-up of the photometer and also contains the interface electronics for speed control of both mirror and luminaire motors, luminaire raise/lower and laser on/off. This allows the operator to align the sample prior to testing.

### **B.5 Instrumentation Rack**

The instrumentation rack comes pre-wired forming the 'control center' for the photometer. As the wiring is inside the instrumentation rack all photometer wiring 'out of view' and adds to the professional presentation of the laboratory system. Additionally, because the control system is supplied pre-wired, laboratory installation time is significantly reduced.



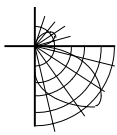

# LightLab R100 Rotating Mirror Intensity Distribution Photometer.

The R100 photometer is supplied with two software packages :

- C1. Control** for machine operation
- C2. Report** to generate test reports.

## C.1 CONTROL FOR WINDOWS

Control of the photometer operations is managed by the program 'CONTROL', which includes the following features :

- Automatic or manual operation of photometer including velocity and seek to position actuation modes.
- All tasks, such as performing a test or calibration of the goniophotometer, are wizard based to ensure accurate and efficient use by laboratory staff. You will even be reminded when to perform calibrations.
- Graphic display of polar distribution and test progress during testing.
- User programmable vertical and luminaire rotation angles and scriptable test formats. Standard test formats pre-programmed to optimise testing throughput and include operation in C<sub>γ</sub> or C-level format. Reporting software will adapt to and make use of all test data logged.
- Automatic logging of acquired data to hard disk.
- Selection of photocell characteristics during all modes of operation.

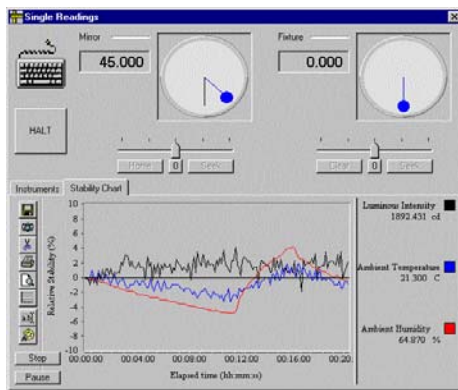
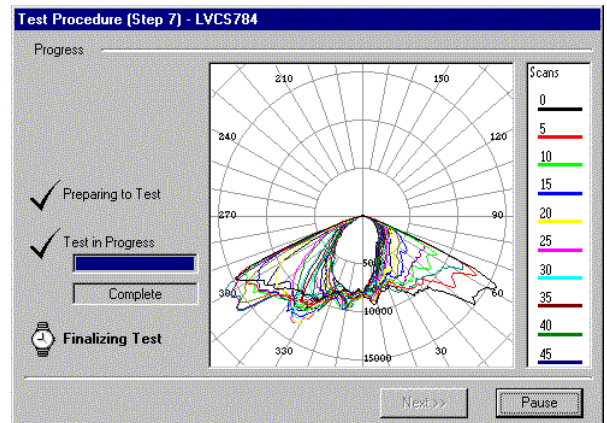

The goniometer control software package is Windows based and allows complete scriptable configuration of the goniometer when performing a test including the number and location of the planes of data and the angles that are sampled in each plane. It comes supplied with predefined test formats to test to local standards. During automatic acquisition all measurements made by the attached instruments are logged in addition to the photometric data.

A 'single readings' mode is included which allows a lamp stability check to be made during setup and testing. Diagnostics are run every time the software is started and whenever a test is run to ensure the goniometer is operating without error. All measurements available from the instrumentation are displayed, including luminous intensity and illuminance and the horizontal and vertical angles in either C<sub>γ</sub> or HV format.

An integral feature of the control software is tracking of sample stability. It provides graphical plotting of all measured parameters versus time, so laboratory staff can check sample stability. This minimises unnecessary warm-up time and increases laboratory efficiency.

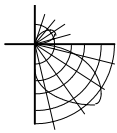

## LightLab R100 Rotating Mirror Intensity Distribution Photometer.

### C.2 REPORT

Report operates as a VBA module under EXCEL and generates its output to a set of pre-programmed spreadsheets. As such the output/printed text is independent of the photometric calculations and thus the text can be customized by the client to meet local requirements. Report has been successfully updated for Chinese language output as required for CNLA for laboratory accreditation.

All of the report types (Interior, exterior, flood, street, lamp) can utilise any data file generated by the Control software allowing the creation of hybrid reports incorporating elements from multiple report types. This allows (for example) isolux curves generated by the Flood module to be easily incorporated into reports for an interior luminaire.

Report allows for the creation of reports based on 5 symmetry types which can be applied regardless of the plane and angle distribution of the photometric data in the data file. The planes of data are intelligently mapped based on an exploration of the data when applying the symmetry. In addition Report supports 4 types of lumen basis : cd per klm, rated lamp lumens, absolute and absolute with nominated lamp lumens.

Summary of available information available from reports :

- Luminous Intensity Data
- Luminous Intensity Distribution Diagrams
- Zonal Luminous Flux Diagrams
- Luminaire Efficiency
- Luminance Distribution
- Coefficient of Utilisation
- Luminance limitation curves
- Polar curves for street lighting as per CIE 34.
- CIE Performance parameters, including throw, control, spread as per CIE 34
- Isolux and isocandela diagrams for streetlights and floodlights
- IESNA, CIE, Eulumdat, CIBSE and Phillum photometric files.

Details of each Report module follow on the next pages.



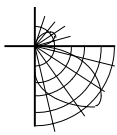

## LightLab R100 Rotating Mirror Intensity Distribution Photometer.

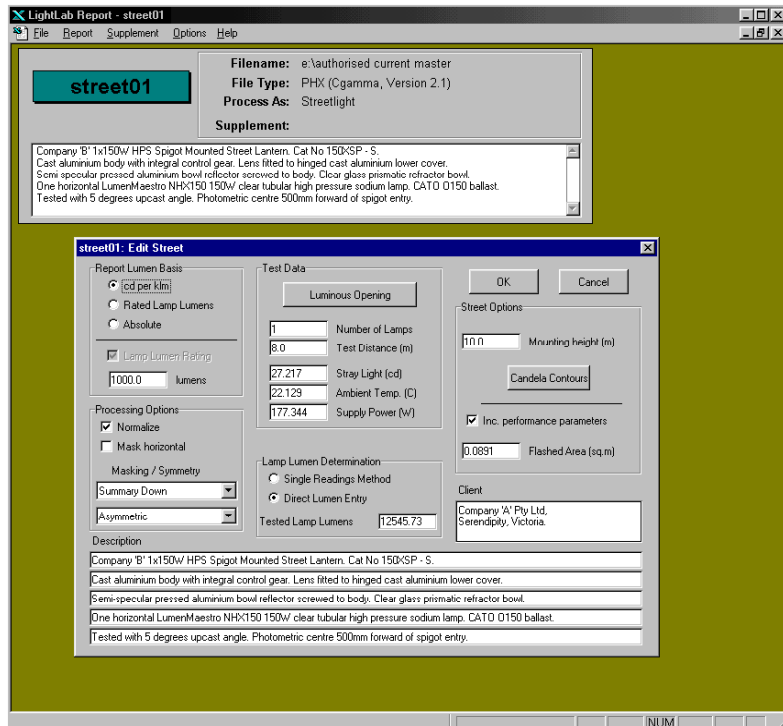

### INTERIOR LUMINAIRE :

General photometric report processing program to generate reports for both indoor and outdoor luminaires as well as bare lamps.

- Suitable for all indoor luminaires, such as:
- fluorescent and CFL (prismatic, louvre, wrap-around, wall wash, upright, etc.)
- incandescent (downlight, upright, wall wash etc.)
- HID (Highbay, Lowbays etc.)
- Bollards and other miscellaneous exterior lights
- IESNA, CIE, Eulumdat, CIBSE and Phillum photometric files.

All the above in symmetric and asymmetric distributions.

Outputs from **REPORT** for interior luminaires include :

- Polar distribution curves.
- Light Output Ratio.
- Average Luminance Summary.
- Coefficient of utilisation (TM5, CIE and IESNA methods).
- Zonal Flux diagram and tables.
- Luminance limiting curve and luminance tables.
- SHR diagram
- Detailed intensity table in 2.5° increments in Gamma, 22.5° in C planes..
- Summary intensity table.
- Zonal lumens.
- IESNA, CIE, Eulumdat, CIBSE and Phillum photometric file formats.
- Luminaire efficiency

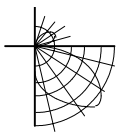

# LightLab R100 Rotating Mirror Intensity Distribution Photometer.

## FLOODLIGHTS

**REPORT** produces photometric reports for all types of floodlights e.g. Axial symmetric, Bi-symmetric and Asymmetric floodlighting luminaires.

Outputs from **REPORT** for floodlights include :

- Summary page noting beam spreads, maximum intensity and Light Output Ratio.
- Intensity trace on rectilinear co-ordinates through C0 and C90 planes.
- Intensity data through C0 and C90 planes.
- Isocandela diagram with lumen distribution.
- 'Standard table' of intensity values and lumens.
- Relative isolux diagram at nominated mounting height.
- IESNA, CIE, Eulumdat, CIBSE and Phillum photometric files.
- Conversion of data for output in B-beta format.

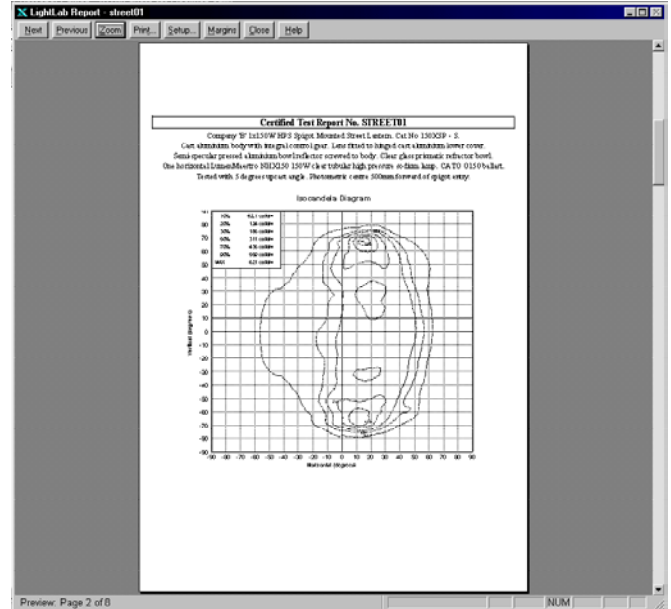

## STREETLIGHTS

**REPORT** produces photometric test reports for streetlights with Axial symmetric and Bi-symmetric luminaire distributions.

Outputs from **REPORT** for streetlights include :

- Summary page noting Light Output Ratios.
- Polar plot through Cone and C-plane of max. intensity and plots according to CIE 34
- Tabulation of intensity data.
- Tabulation of summary intensity data.
- Plot of 90% Imax contour for CIE classification and SLI.
- Relative Isolux and isocandela diagrams at nominated mounting height.
- IESNA, CIE, Eulumdat, CIBSE and Phillum photometric files.
- CIE performance parameters : throw, control and spread

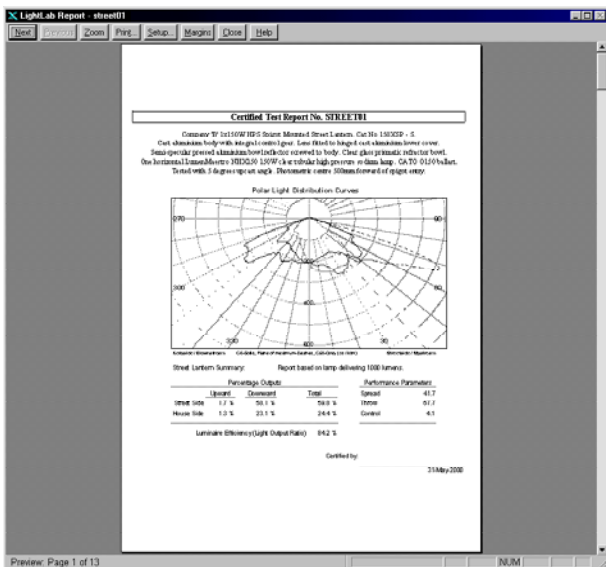

## LAMP:

**REPORT** processes lamp tests to determine the lumen output of any type of lamp.

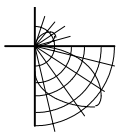

## LightLab R100 Rotating Mirror Intensity Distribution Photometer.



### D.1 Power meters

The system optionally includes two Yokogawa WT200 wattmeters fitted into the control room instrumentation rack complete with one precision shunt wired onto the photometer. Wattmeters are connected via IEEE instrumentation bus to the computer. One wattmeter is used to measure lamp volts, amps & watts, the other for total circuit (lamp+ballast) volts, amps & watts.

For higher precision measurements and measurement of 3 phase inputs there is the option of using either a Yokogawa WT130 or a Voltech PM3000ACE meter instead of the WT200. Combinations of meters are supported to measure the electrical parameters at more than one point or a single Voltech PM3000ACE can be configured to measure at two points.

Measurement system	3 phase
Basic accuracy	0.05%
Bandwidth	DC and 0.1Hz to 1 MHz
Measurements	W, V, A, VA, VAR, power factor, Cos, Vpk, Apk, crest factors, frequency and inrush current, transients
Harmonics	A, V, (incl. Phase) and W to the 99th. THD Integrator for W-hr, VA-hr, A-hr, VA-hr, Average and target PF Crest factors up to 20
Integration	W-hr, VA-hr, A-hr, VA-hr, Average and target PF

System measurement specifications with PM3000ACE option

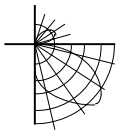

## LightLab R100 Rotating Mirror Intensity Distribution Photometer.

### **D.2 Stabilised power supply.**

LightLab recommends California Instruments stabilised AC power sources. There are a range of models available to suit your requirements. Model 5000iM will allow operation to 5000VA, single phase output. Model 4500L also operates to 5000VA and has a 3 phase output.

### **D.3 Temperature Indicator.**

The system includes one HP Data Acquisition Unit configured as a digital thermometer, mounted into instrumentation rack and connected via IEEE instrumentation bus to the control computer. RTD temperature sensor is built into the photometer.

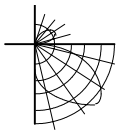

## LightLab R100 Rotating Mirror Intensity Distribution Photometer.

### **E.1 Training at Client site (standard training)**

Standard training is 3 days at the Client's site on completion of the photometer installation. The engineers will be trained in all aspects of standard laboratory procedures such as calibration, luminaire checkin, preparation, testing and production of final test reports.

Additional training can be provided if required, please refer to options below.

### **E.2 Initial training at LightLab's test facility in Melbourne, Australia (optional)**

Initial training of two engineers for a period of one week will be provided at LightLab's facilities in Melbourne, Australia. LightLab will arrange for all accommodation, meals, transport etc. Training is an expanded version of that offered in item E.1 above. This is an option that must be specified at time of order.

### **E.3 Installation at Client site (optional)**

LightLab will provide two engineers for one week to aid system installation at the Client's premises. If additional installation time is required it can be provided, please refer to options.

### **E.4 Pre-installation setup and advice (optional)**

LightLab will provide advice to the client to help setup the laboratory system including such items as air-conditioning, electrical power, provision of laboratory space, customer specific jigs etc. which are not a part of this quotation. LightLab will send one engineer to the client's facility after receipt of L/C for discussions on the proposed laboratory setup. This is an option that must be specified at time of order.

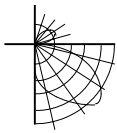

## LightLab R100 Rotating Mirror Intensity Distribution Photometer.

**F. R100 Mirror photometer summary:**

**The R100 comprises:**

- R100 rotating mirror goniophotometer with single section superstructure
- Integral hand controller and detached photodetector housing
- Built in lasers for mirror and luminaire axis and remote wall laser
- Thermally stabilised photodetector and 5 ½ digit display
- Computer, computer interface and control and measurement instrumentation in laboratory grade instrumentation rack
- Computer software for control of goniometer and report creation
- Installation and training
- All instruction manuals
- Warranty for 1 year

**Options**

<i>Item</i>	<i>Description</i>	<i>Qty</i>
MaintR100	<b>Maintenance contract</b> LightLab will maintain and service the goniophotometer system upon expiry of the warranty. Maintenance includes annual calibration, software updates, training courses and servicing where required.	1
StVAR100	<b>Power Stabilisers</b> California Instruments range of power stabilisers as detailed below : 800VA – single phase, CI Model 800RP : StVAR1008kV1 1000VA – single phase, CI Model 1000P : StVAR1001kV1 1250VA – single phase, CI Model 1250RP : StVAR100125kV1 2000VA – single phase, CI Model 2001RP : StVAR1002kV1 2000VA – three phase, CI Model 2003RP : StVAR1002kV3 3000VA – single phase, CI Model 3000iM : StVAR1003kV1 5000VA – single phase, CI Model 5000iM : StVAR1005kV1 5000VA – three phase, CI Model 4500L : StVAR1005kV3	1
TiltR100	<b>Tilt functionality for mirror</b> Allows the mirror to be tilted so the goniophotometer system can support different test distances.	1
LISR100L	<b>Luminous Intensity Standard Lamps – LightLab</b> One set of three intensity standard incandescent lamps, medium bi-post base, 110V 1000W including one 4 contact kelvin socket. Used for intensity calibration of the photometer. Lamps come serialized and with LightLab (NML) calibration certificates.	Set of 3 lamps

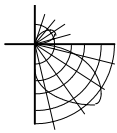

## LightLab R100 Rotating Mirror Intensity Distribution Photometer.

LISR100	<p><b>Luminous Intensity Standard Lamps – NML</b></p> <p>One set of three intensity standard incandescent lamps, medium bi-post base, 110V 1000W including one 4 contact kelvin socket. Used for intensity calibration of the photometer. Lamps come serialized and with National Measurement Laboratory (NML) calibration certificates.</p>	Set of 3 lamps
LSR100L	<p><b>Lumen Standard Lamps – LightLab</b></p> <p>One set of three lumen standard incandescent lamps, E27 base, 240 or 110V 150W. Lamps come serialised and with LightLab calibration certificates.</p>	Set of 3 lamps
LSR100	<p><b>Lumen Standard Lamps – NML</b></p> <p>One set of three lumen standard incandescent lamps, E27 base, 240 or 110V 150W. Lamps come serialised and with National Measurement Laboratory (NML) calibration certificates.</p>	Set of 3 lamps
LmpR100	<p><b>Lamps</b></p> <p>Other lamps can be supplied with the system. Typically the lamps will be supplied in groups of 3 and calibrated for luminous flux and / or spectral output at client request. The lamps can be of types : compact fluorescent – LmpR100CFL, high pressure sodium – LmpR100HPS, metal halide - LmpR100MH, or incandescent -LmpR100Inc. Specify wattage and type at time of order, enquire for other types.</p>	Set of 3 lamps
BalR100	<p><b>Reference Ballasts</b></p> <p>Reference ballasts to suit lamps under LmpR100 The ballasts can be of type compact fluorescent - BalR100CFL, high pressure sodium – BalR100HPS, metal halide – BalR100MH. Ballasts come with calibration certificate. Specify wattage and type at time of order, enquire for other types.</p>	1
LMFR100	<p><b>Lamp Mounting Fixtures</b></p> <p>Painted brass mounting tubes with 4 wire E27 and E40 bases. The fixtures include all mounting accessories to secure lamps to goniophotometer. Others available on request.</p>	1
LMFR100DE	<p><b>Double ended Fluorescent Lamp Mounting Fixtures</b></p> <p>Painted brass mounting tube with adjustable fluorescent lamp holder between 10 and 40W, to suit T5 or T8 lamps</p>	Each
PTR100	<p><b>Printer</b></p> <p>HP Laserjet 1200 1200 DPI laser configured for LightLab software or HP Deskjet Cxi960 colour inkjet printer. Other printers available on request.</p>	1
TIPreR100	<p><b>Pre-Installation Inspection</b></p> <p>LightLab will provide one engineer for a 3 day pre-installation visit to inspect and arrange installation of the laboratory.</p>	1
TIEXR100	<p><b>Training &amp; Installation Extensions</b></p> <p>LightLab will provide training and installation service of 3 days and 1 week respectively as part of the core service. This option allows extension of the training and installation to your requirements.</p>	1



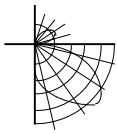

## LightLab R100 Rotating Mirror Intensity Distribution Photometer.

WTR100	<b>50kHz Wattmeter</b> Yokogawa WT200 50kHz single phase wattmeter with rack mounting kit, IEEE-488 interface and integrated into LightLab testing software. Used to measure lamp operating parameters. Specify WTRLampR80 for wattmeter setup for measurement of lamp parameters and/or WTRSupplyR80 for wattmeter setup for measurement of supply parameters.	1
WTR1003	<b>3 Phase Wattmeter</b> Yokogawa WT103 three phase wattmeter with rack mounting kit, IEEE-488 interface and integrated into LightLab testing software. Used to measure electrical operating parameters.	1
WTPR1003	<b>High Precision 3 Phase Wattmeter</b> Voltech PM3000A three phase wattmeter with rack mounting kit, IEEE-488 interface and integrated into LightLab testing software. Used for high precision measurement of electrical operating parameters.	1
SS1PR100	<b>Stabilised power supply, single phase output</b> Stabilised power supply, single phase output. Models with power capabilities to 1000VA, 2000VA, 3000VA and 5000VA are available	1
SS3PR100	<b>Stabilised power supply, three phase output</b> Stabilised power supply, single phase output. Models with power capabilities to 2000VA and 5000VA are available	1
AGIR100	<b>Lighting Design Software</b> AGI32 is world class Lighting Design Software that extends the utility of the laboratory results: from photometric test to full fledged lighting design.	1
PhotR100	<b>Photocell</b> Choose from a range of precision photocells to increase the accuracy of measurement for the goniometer system. The characteristics and upper limits of operation for the CIE parameters common to all of the photocells are listed in the photocell table below. Other CIE parameters determined at request of client.	1
FiltR100	<b>Coloured and Neutral density filters</b> For calibration of the photocell according to the method of CIE Pub 24. This allows field verification of the system performance in terms of spectral response and linearity.	1
2yR100	<b>2 year warranty</b> This option gives a one year extension to usual one year system warranty, total 2 years.	1

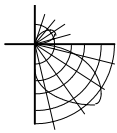

## LightLab R100 Rotating Mirror Intensity Distribution Photometer.

Characteristic	Symbol for associated error parameter	Maximum Value
V( $\lambda$ ) match	f1	1.5 %
Cosine Response	f2	-
Linearity	f3	0.1%
Error of display unit	f4	0.2 %
Fatigue	f5	0.2%
Evaluation of modulated light	f7	-
Polarization dependence	f8	-
Influence of non-uniform illumination	f9	1.0 %
Range change	f11	0.1%
UV response	U	0.2%
IR response	R	0.2%
Temp. dependence	A	0.2 % / K
Responsivity		30, 60 or 120nA / lux

Photocell Table 1 – for CIE parameters not listed here please contact LightLab for specifications